

Hot Rod Front Disc Brake Kits

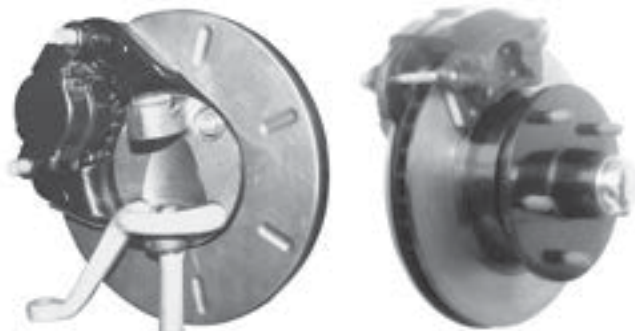

SUPERBELL POWER STOPPER DISC BRAKE KIT

Designed for 3000 lb. cars and heavier. Fits 1939-48 Ford passenger car or Chassis Engineering reproduction spindles and 1948-56 Ford pickup spindles. Includes: brackets, bearings, seals, hardware, backing plates, hubs, rotors, calipers. Specify bolt pattern, 4-1/2", 4-3/4", 5", or 5-1/2".

1135 1939-48 Ford car, 1948-56 Ford Pickup .. \$569.95



SUPERBELL BASIC HOT ROD DISC BRAKE KIT

Adapts a wide range of rotors and GM 1978-86 intermediate (metric) calipers to 1939-48 Ford passenger car or Chassis Engineering reproduction spindles and 1948-56 Ford pickup spindles. Includes: brackets, bearings, seals, hardware, rotors, calipers. Specify bolt pattern, 4-1/2" or 4-3/4".

1125K 1939-48 Ford car, 1948-56 Ford Pickup
Basic Brake kit \$375.00

1125 Basic Brake kit, brackets/bearings only .. \$120.00



LOW BUCK BRAKE KIT

Adapts most 1970-77 intermediate GM calipers and rotors to 1937-48 Ford spindles. No machining is required.

Low Buck Brake Kit \$110.00



ECI DISC BRAKE KITS FOR STOCK SPINDLES

ECI's Disc Brake kits bolt-on to stock or reproduction spindles. Kits include: GM full size car calipers/pads (bigger than the GM intermediate calipers), Factory 11" rotors with Ford or GM bolt pattern, bearings/adapters, seals, hardware, brackets and instructions. Available as brackets, bearings and hardware only or complete with rotors and loaded calipers

1937-48 FORD CARS / 37-47 FORD P/U

- EC-701** GM 4-3/4" Bolt CircleBasic Kit **\$160.00**
- EC-701CK** Complete Kit **\$425.00**
- EC-709** FORD 4-1/2" Bolt Circle.....Basic Kit **\$160.00**
- EC-709CK** Complete Kit **\$450.00**
- EC-730** FORD 5-1/2" Bolt Circle.....Basic Kit **\$160.00**
- EC-730CK** Complete Kit **\$450.00**

NOTE: Aftermarket spindles require modified steering arms.

1948-56 FORD PICKUP (1/2 TON)

- EC-705** GM 4-3/4" Bolt CircleBasic Kit **\$160.00**
- EC-705CK** Complete Kit **\$450.00**
- EC-710** FORD 4-1/2" Bolt Circle.....Basic Kit **\$160.00**
- EC-710CK** Complete Kit **\$450.00**
- EC-731** FORD 5-1/2" Bolt Circle.....Basic Kit **\$160.00**
- EC-731CK** Complete Kit **\$450.00**

1957-64 FORD PICKUP (1/2 TON)

- EC-732** FORD 5-1/2" Bolt Circle.....Basic Kit **\$160.00**
- EC-732CK** Complete Kit **\$450.00**

1949-53 FORD, 53-53 MERCURY

- EC-721** GM 4-3/4" Bolt CircleBasic Kit **\$170.00**
- EC-721CK** Complete Kit **\$425.00**
- EC-721F** FORD 4-1/2" Bolt Circle.....Basic Kit **\$230.00**
- EC-721FCK** Complete Kit **\$450.00**

1954-56 FORD/MERC, 55-57 T-BIRD

- EC-733** FORD 4-1/2" Bolt Circle.....Basic Kit **\$275.00**
- EC-733CK** Complete Kit **\$450.00**

1957-64 FORD/MERCURY

- EC-734** FORD 4-1/2" Bolt Circle.....Basic Kit **\$275.00**
- EC-734CK** Complete Kit **\$450.00**

1965-70 MUSTANG

- EC-737CK** FORD 4-1/2" Bolt Circle..... Complete Kit **\$575.00**

1949-54 CHEVY PASSENGER CAR AND 53-62 CORVETTE

- EC-702** GM 4-3/4" Bolt CircleBasic Kit **\$180.00**
- EC-702CK** Complete Kit **\$450.00**

1937-40 CHEVY PASSENGER CAR with original I.F.S.

- EC-707** GM 4-3/4" Bolt CircleBasic Kit **\$180.00**
- EC-707CK** Complete Kit **\$450.00**

1941-48 CHEVY PASSENGER CAR with original I.F.S.

- EC-706** GM 4-3/4" Bolt CircleBasic Kit **\$180.00**
- EC-706CK** Complete Kit **\$450.00**

1937-40 CHEVY PASSENGER CAR AND PICKUP with Straight Axle

- EC-711S** GM 4-3/4" Bolt CircleBasic Kit **\$180.00**
- EC-711SCK** Complete Kit **\$450.00**

1941-54 CHEVY PASSENGER CAR AND PICKUP with Straight Axle

- EC-711** GM 4-3/4" Bolt CircleBasic Kit **\$180.00**
- EC-711CK** Complete Kit **\$450.00**

ECI DISC BRAKE KITS FOR STOCK SPINDLES (cont.)

- 55-58 CHEVROLET PASSENGER CARS** with stock spindles
- EC-708 GM 4-3/4" Bolt Circle Basic Kit **\$175.00**
 EC-708CK Complete Kit **\$450.00**
 EC-708ACK Alum Hub, zero offset Complete Kit **\$575.00**
- 59-64 CHEVY PASSENGER CAR**
- EC-712 GM 4-3/4" Bolt Circle Basic Kit **\$175.00**
 EC-712CK Complete Kit **\$450.00**
 EC-712ACK Alum Hub, zero offset Complete Kit **\$575.00**
- 65-68 Chevy passenger car**
- EC-729 GM 4-3/4" Bolt Circle. Basic Kit **\$175.00**
 EC-729CK Complete Kit **\$450.00**
 EC-729ACK Alum Hub, zero offset Complete Kit **\$575.00**
- 55-59 Chevy Pickup**
- EC-711X GM 4-3/4" Bolt Circle Basic Kit **\$180.00**
 EC-711XCK Complete Kit **\$450.00**



WILWOOD FRONT DISC BRAKE KITS Forged Dynalite Pro Series Front Brake Kit 4 pistons, 11" rotors

FDL Pro-Series Front Hub Kits offer complete disc brake upgrade solutions for muscle cars, street rods, and 50s cars. Based on the forged billet Dynalite caliper, these require no modifications for installation, and provide plenty of clearance inside popular 15" wheels. FDL Pro-Series kits can be used with either manual or power boost master cylinders. Black anodized calipers, solid rotors standard. Optional caliper finishes and drill/slotted rotors available.

- 140-11491 1955-57 Chevy. **\$772.74**
 140-11811 1949-1954 Chevy/ 1953-1962 Corvette ... **\$764.16**
 140-11017 1971-18 Mustang II. **\$764.16**
 140-11013 1937-48 Ford Spindle (polished optional) . **\$764.16**
 140-11099 1980-1987 GM G-Body, Malibu, Buick GN . **\$764.16**
 140-10996 1967-69 Camaro, 1964-1974 A-Body. **\$775.94**
 140-11007 1970-78 Camaro / Firebird **\$764.16**
 140-11012 1982-90 Camaro / Firebird **\$764.16**



JOHN'S INDUSTRIES REAR DRUM BRAKE KIT

These rear drum brakes are assembled and ready to install. Fits the popular "Torino" style flanges. Available in 10" x 2-1/2" and 11" x 2-1/2" with 12" backing plate. Our 10" brake kit weighs only 45 lbs! Less unsprung weight equals a better ride. This is the best street rod brake kit ever!

- 10" Ford Drum Brake Kit **\$425.00**



EC-704, 739ACK

SuperLite 6R Front Brake Kit-6 pistons, 12.88"rotors

SL6R forged billet six-piston caliper disc kits are built exclusively for 17" and larger wheels. A full range of options for caliper finishes and rotor designs are available.

- 140-10737 1955-57 Chevy (may fit some 15") **\$1,331.72**
 140-9801 1971-18 Mustang II (original disc spindles) . . **\$1,903.94**
 140-10739 1937-48 Ford Spindle (may fit some 15") . . **\$1,153.64**
 140-9803 1967-69 Camaro, 1964-1974 A-Body **\$1,903.94**
 140-10485 1970-78 Camaro / Firebird* ** **\$1,903.94**

*May require modifications to stock spindles. **11" rotor spindles only

1974-78 MUSTANG II/1973-80 PINTO SPINDLES

ECI kit uses stock big piston GM calipers and 11 inch GM or Ford rotors. Available as brackets, bearings and hardware only or complete with rotors and loaded calipers.

- EC-703 GM 4-3/4" Bolt Circle-3/4" OFFSET. .Basic Kit **\$150.00**
 EC-703CK Complete Kit **\$450.00**
 EC-722 GM 4-3/4" Bolt Circle- NO OFFSET. .Basic Kit **\$150.00**
 EC-722CK Complete Kit **\$450.00**
 EC-716 FORD 4-1/2" B.C. -5/16" OFFSET . .Basic Kit **\$180.00**
 EC-716CK Complete Kit **\$450.00**
- ZERO OFFSET with ALUMINUM HUBS (shown)**
- EC-704CK FORD 4-1/2" or GM 4-3/4".... Complete Kit **\$575.00**
 EC-739ACK GM 5" Bolt Circle Complete Kit **\$600.00**
 EC-739BCK FORD 5-1/2" Bolt Circle Complete Kit **\$625.00**

HEIDTS MUSTANG II DISC BRAKE CONVERSIONS

Upgrade your Mustang II spindles to 11" rotors. Use 78 and up GM calipers available as a bracket kit only or as a complete kit including calipers and rotors. Also with Wilwood calipers.



- DF-101-F Basic disc kit, Ford rotors. **\$99.00**
 DF-201-F Ford disc kit complete **\$349.00**
 DF-101-C Basic Kit, Chevy rotors **\$120.00**
 DF-201-C Chevy disc kit complete **\$399.00**
 DF-202 Kit with 4 piston Wilwood calipers* **\$618.00**

*specify bolt circle

Call 402.886.2275 or click: www.heinzmanstreetrods.com

Hot Rod Front Disc Brake Kits

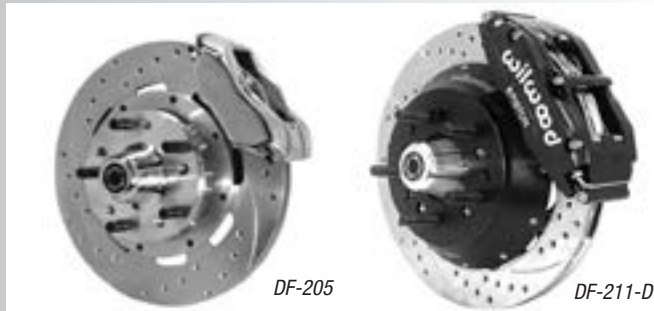

WILWOOD DISCS BRAKES FOR HEIDTS SPINDLES

Big disc brake kits designed for Heidts Mustang II and 55-57 Chevy dropped spindles. Include 4-piston Wilwood calipers with 11 or 12" plain or Zinc cross-drilled/slotted rotors or 13" rotors with 6-piston calipers. Will also work with most Mustang II spindles.

FOR HEIDTS MUSTANG II DROPPED SPINDLES

DF-202-B	11" Smooth rotors, black calipers	\$871.00
DF-202-P	11" Smooth Rotors, polished calipers	\$886.00
DF-202-R	11" Smooth Rotors, red calipers	\$966.00
DF-202-D-B	11" Drilled rotors, black calipers	\$986.00
DF-202-D-P	11" Drilled Rotors, polished calipers	\$1000.00
DF-202-D-R	11" Drilled Rotors, red calipers	\$1087.00
DF-208-B	12" Drilled rotors, black calipers	\$1,060.00
DF-208-P	12" Drilled Rotors , polished calipers	\$1,065.00
DF-208-R	12" Drilled Rotors, red calipers	\$1,147.00
DF-206-B	13" Drilled Rotors & 6 piston black cal	\$1,970.00
DF-206-P	13" Drilled Rotors & 6 piston polished	\$2,069.00
DF-206-R	13" Drilled Rotors & 6 piston red cal	\$2,133.00

FOR HEIDTS 1955-57 CHEVY DROPPED SPINDLES

DF-205	11" Drilled Rotors, polished calipers	\$895.00
DF-205-D	11" Drilled Rotors, polished hubs/calipers	\$1,050.00
DF-210-D	12" Drilled Rotors, polished hubs/calipers	\$1,075.00
DF-211-D	13" Drilled Rotors, black hubs/calipers	\$1,995.00



ECI REAR DISC BRAKE CONVERSIONS FOR GM, FORD AND CHRYSLER REAR AXLES

The ECI rear disc brake conversion kits adapts Cadillac Seville/Eldorado rear calipers and 11 inch rear rotors to 8, 8.8 and 9" Ford and GM 10 and 12 bolt GM ("C" clip type), 55-64 Chevy and 8-3/4"/Dana 60 type rear axles assemblies. Calipers utilize the OEM integral parking brake mechanism and standard GM pads. These conversions are the easiest way to upgrade to rear disc brakes with a functional OEM style parking brake.

Kits are supplied complete with rebuilt rear caliper assemblies with pads, new 11 inch diameter rotors (11-3/4" on EC-843), caliper brackets and mounting hardware. Axle bearing removal is NOT required for installation.

NOTE: Minor axle flange machining is required for rotor installation on some Ford and GM installations. Chrysler product rear axles require one piece "GREEN" axle bearings.

FORD REAR ENDS

EC-840	8" and 9" rear axles, small flange 4-1/2" bolt circle	\$575.00
EC-841	8" and 9" rear axles, large flange 4-1/2" bolt circle	\$575.00
EC-841LV	Lincoln Versailles retrofit kit	\$625.00
EC-842	8" and 9" rear axles, new style flange, 4-1/2" bolt circle	\$575.00
EC-843	9" rear axles, 5-1/2" bolt circle	\$575.00
EC-847	8.8" rear axles Ford, 5 lug axles only 4-1/2" bolt circle	\$575.00

GM REAR ENDS

EC-844	GM 10 and 12 bolt rear axles w/axle retainers only 4-3/4" bolt circle, (w/o "C" clip)	\$575.00
EC-845	GM 10 and 12 bolt rear axles with "C" clip only 4-3/4" bolt circle,	\$575.00
EC-845A	same as above for big car housing ends.	\$575.00
EC-845B	same as above for 5 inch bolt circle	\$575.00
EC-846	1955-64 Chevy rear axles, 4-3/4" bolt circle	\$575.00
EC-848	1973-94 Chevy/GMC 1/2 ton pickup with "C" clip axle retainers only, 5" bolt circle	\$575.00

CHRYSLER REAR ENDS

EC-849	Chrysler 8-3/4" and Dana 60	\$575.00
--------	---------------------------------------	----------

All Above w/13 in. dia. rotors add \$100.00

Hot Rod Front and Rear Disc Brake Kits





WILWOOD PRO SERIES REAR AXLE KITS

Internal parking brake fits 15" and up wheels. Also available without parking brake.

Forged billet Dynapro Low-Profile four-piston calipers, 11.00" one-piece hat and rotor assemblies, and high friction pads. The neatly hidden internal shoe system provides a clean installation with superior static holding power for parking. Black anodized calipers, solid rotors standard. Optional caliper finishes and rotor designs available.

All kits with black calipers and parking brake \$659.95

All kits with black calipers w/o parking brake \$558.95

Add for red powder coated calipers . . . pr \$100.80

Add for Drilled & Slotted rotors pr \$112.00

140-11405 1955-57 Chevy / 56 Corvette, 2.34" offset . . .

140-11827 1959-64 Impala / 57-62 Corvette, 2.91" offset . .

140-11397 Olds/Pontiac, 2.81" offset

140-11403 Small Ford, 2.50" offset

140-11387 Big Ford, 2.36" offset

140-11402 Big Ford (New Style), 2.36" offset

140-11390 8.8 Mustang, 2.50" offset

140-11385 Chevy C10, 2.42" offset.

140-11395 Mopar/Dana, 2.36" offset.

140-11386 Mopar/Dana, 2.50" offset.

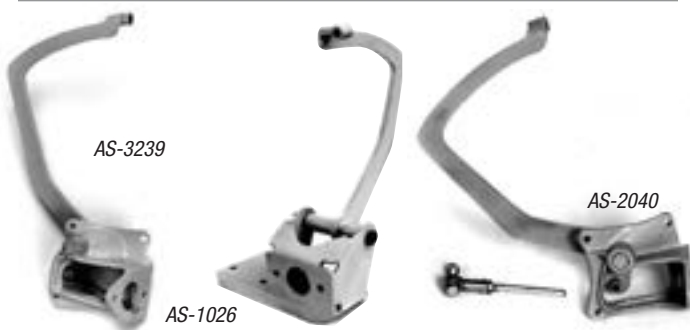

BRAKE PEDAL KIT

Designed for use with Mustang cylinder.

AS-3240 Model A (mounts to boxed frame) \$120.00

AS-3239 1932 Ford (mounts to boxed frame) \$120.00

AS-2034 1934 Ford (mounts to boxed frame) \$145.00

AS-2040 1935 to 40 Ford (mounts to stock X) \$145.00

AS-1026 1937 to 39 Chevy \$160.00

AS-1041 1940-48 Chevy. \$77.25



MASTER CYLINDER ADAPTER

This kit bolts a Pinto-Mustang master cylinder to the original 1941-1948 Ford brake pedal assembly. Includes adapter, new shaft, spacers, bolts and instructions. Kit spaces pedal assembly over to clear Turbo 350. Some fitting is required.

AS-2022 Adapter kit \$55.00

AU2036 Mustang 15/16" bore, standard \$82.30

AU-2037 Mustang 1" bore, standard. \$82.30



POWER BRAKE ADAPTER

Adapts Chassis Engineering Power booster or stock Pinto booster assembly to the 1939-1948 Ford pedal. This is a good fit and well worth doing.

AS-2058 \$69.00



MASTER CYLINDERS

State usage when ordering.

7/8" bore single, manual disc/drum \$79.00

1" bore single, power disc/drum or disc/disc \$79.00

AU-2036 Mustang 15/16" bore, standard or power. . \$79.00

AU-2037 Mustang 1" bore, standard or power \$79.00

AU-2041 Remote Fill 15/16" bore, power only \$78.70

AU-2042 Remote Fill 1" bore, power only. \$92.00

AU-2043 Remote Fill 1-1/8" bore, power only \$129.00

Corvette 1" bore \$85.20

Wilwood 7/8" bore \$199.00



POWER BRAKE BOOSTER- DUAL DIAPHRAGM

This 7 inch dual booster is an ideal size for most street rods

AS-2075 7 inch dual booster \$125.00

8531 8 inch dual booster \$125.00

Call 402.886.2275 or click: www.heinzmanstreetrods.com

Hot Rod Rear Disc Brake Kits and Components

Hot Rod Brake Components



ECI MASTER CYLINDER/BOOSTER PEDAL ASSEMBLIES

These are brand new 7" boosters assembled with a new Corvette 1 inch bore 4 wheel disc brake master cylinder. They are pressure and vacuum tested before being shipped to you. They can be used on a disc/drum brake combination by installing a GM factory proportioning valve with built in residual pressure valve for the drum brakes. Pedal assemblies mount under the floor and include bracket, pedal and hardware.

- EC-500** 1928-32 Ford (and universal) brake pedal/power booster mounting assembly. This mount welds to a boxed 28-32 type chassis **\$425.00**
- EC-510** 1933/34 Ford, master/booster/pedal mnt. . . **\$425.00**
- EC-520** 1935-40 Ford, master/booster/pedal mnt. . . **\$425.00**
- EC-520A** 1941-48 Ford, master/booster/pedal mnt. . . **\$425.00**
- EC-600** 1955-64 Chevrolet Passenger Car master/booster/mounting bracket **\$295.00**
- EC-605** 1955-64 Chevy w/9" power booster **\$325.00**
- EC-610** 1962-67 Nova master/booster/mounting bracket **\$295.00**
- EC-615** 1964-66 Chevelle master/booster/mounting bracket **\$325.00**
- EC-505** 1947-54 Chevy pick-up **\$395.00**
- EC-515** 1955-59 Chevy pick-up. **\$395.00**
- EC-524** 1948-52 Ford 1/2 ton Pickup **\$425.00**
- EC-522** 1953-56 Ford 1/2 ton Pickup **\$425.00**
with standard shift, add **\$50.00**



EC-515 shown



EC-420 shown

ECI MASTER CYLINDER ADAPTER

A neat, no hassle way to update to a modern dual master cylinder. Bolts either a Mustang or Corvette master cylinder to the stock brake pedal in the stock master cylinder location. Supplied with push rod, rod end, hardware and new boot. Master cylinder not included.

- EC-410** 1939-40 Ford car **\$49.95**
- EC-415** 1941-48 Ford car **\$99.95**
- EC-450** 1949-51 Ford car **\$219.95**
- EC-410A** 1948-52 Ford pickup. **\$49.95**
- EC-420** 1953-56 Ford pickup. **\$84.95**
- EC-412** 1957-62 Ford pickup. **\$84.95**
- EC-430** 1937-39 Chevy car **\$129.95**
- EC-440** 1940-54 Chevy car (automatic only) **\$129.95**
- EC-440S** 1940-54 Chevy car (standard shift) **\$159.95**
- EC-850** 1953-62 Corvette. **\$250.00**
- EC-420** 1947-54 Chevy pickup **\$89.95**
- EC-425** 1955-59 Chevy pickup **\$110.00**



ECI POWER BRAKE BOOSTER/MASTER CYLINDER

This power brake booster/master cylinder is engineered and designed specifically for street rod applications. Small 7" diameter booster fits under the floor for out of the way installation. The ECI street rod booster is equipped with the right components to provide the right performance and sensitivity for street rod use. It provides power brake performance with dual master cylinder safety. These are brand new boosters assembled with a new Corvette 1" bore 4 wheel disc brake master cylinder. They are pressure and vacuum tested before being shipped to you. They can be used on a disc/drum brake combination by installing our GM factory proportioning valve with built in residual pressure valve for the drum brakes.

- EC-490** 7" dia. booster/master cylinder **\$225.00**
- EC-590** 8" dia. booster/master cylinder **\$225.00**
- EC-495** Remote fill master cylinder kits with fittings, lines, plastic reservoir, bracket for above . . . **\$189.95**



HIGH-POWER ELECTRIC BOOSTER AND MASTER CYLINDER ASSEMBLY

This high pressure system uses an electric remote booster that can be mounted anywhere in the car. This cleans up the firewall, frees up extra valve cover clearance and solves the low vacuum problem that many high performance engines have. Good looking, light weight and easy to install. Features a 1-3/16" bore, dual circuits and built in metering/proportioning valve. Only 8" x 3.6" x 3.3". The electric unit is only 8" x 6" x 6". System also has a hydraulic accumulator that stores pressure and provides 10-15 boosted stops if the electrical system fails. After that, you have normal manual brakes.

- 10-56** Electric power brake booster/M.C. **\$1,400.00**



REMOTE FILL TANK

Milled aluminum tank for remote filling of master cylinder. Includes adapters for cylinder. All fittings are 1/8" pipe. Can be connected with hose or braided line. A quality piece. Use with remote fill master cylinder.

- AS-2060** Remote fill tank. **\$120.00**



PROPORTIONING VALVE

For disc/drum or 4 wheel disc brake systems.

Wilwood Adjustable \$49.95



RESIDUAL PRESSURE CHECK VALVE

10 pound valve: drum brakes. \$22.00

2 pound valve: disc brakes. \$22.00



BULKHEAD FITTINGS

Takes the brake line thru the frame rail instead of around it. Stainless Steel with 1/8" pipe fittings on both ends.

AU-0071 Bulkhead Fittings- for 2" thick frame rail . . \$45.00



BRAKE HOSE KITS

Show quality braided stainless steel brake hoses. Specify type of calipers: GM, Wilwood, Mustang

Brake Hose Kits \$65.00

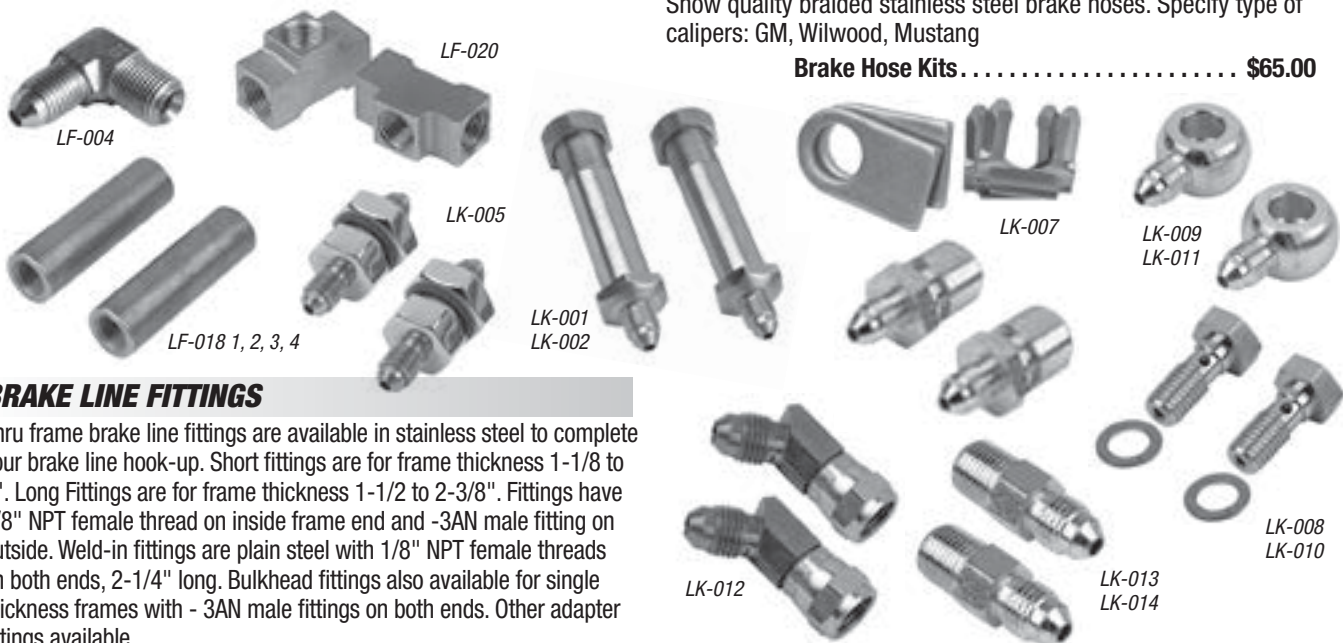

BRAKE LINE FITTINGS

Thru frame brake line fittings are available in stainless steel to complete your brake line hook-up. Short fittings are for frame thickness 1-1/8 to 2". Long Fittings are for frame thickness 1-1/2 to 2-3/8". Fittings have 1/8" NPT female thread on inside frame end and -3AN male fitting on outside. Weld-in fittings are plain steel with 1/8" NPT female threads on both ends, 2-1/4" long. Bulkhead fittings also available for single thickness frames with -3AN male fittings on both ends. Other adapter fittings available.

- LF-004 90 Degree Fitting, -3AN to 1/8" NPT \$13.95**
- LF-011 Weld-on Tab each \$1.95**
- LF-012 Fitting, -3 An To 3/16 Inverted Flair each \$6.90**
- LF-013 Tab Fitting Clip each \$1.00**
- LF-014 Banjo Fitting, 10 mm to -3" each \$13.00**
- LF-015-A 10 mm Banjo Fitting Bolt. each \$4.25**
- LF-015-W 10 mm Banjo Fitting Washer. Each \$0.89**
- LF-018-1 Thru Frame Fitting Weld-In Kit 1/8" NPT to 1/8" NPT (2-1/8" Long) \$12.50**
- LF-018-2 Thru Frame Fitting Weld-In Kit 1/8" NPT to 1/8" NPT (2-1/4" Long) \$12.50**
- LF-018-3 Thru Frame Fitting Weld-In Kit 1/8" NPT to 1/8" NPT (2-1/2" Long) \$12.50**
- LF-018-4 Thru Frame Fitting Weld-In Kit 1/8" NPT to 1/8" NPT (3-1/4" Long) \$12.50**
- LF-020 Inverted Flare T-Fittings (3/16") \$8.20**

- LK-001 Thru Frame Kit, short -3 AN to 1/8" NPT . . . \$45.95**
- LK-002 Thru Frame Kit, long -3 AN to 1/8" NPT . . . \$45.95**
- LK-003 Thru Frame Kit, short 1/8" NPT to 1/8" NPT . \$45.95**
- LK-004 Thru Frame Kit, long 1/8" NPT to 1/8" NPT . . \$45.95**
- LK-005 Thru Frame Bulkhead Kit -3 AN to -3AN" . . \$55.95**
- LK-007 Weld-On Tab Fitting Kit, -3AN To 3/16 Inverted Flair Fittings With Tabs & Clips \$16.50**
- LK-008 Banjo Bolt Kit - Bolts & Washers (10 mm) . . \$11.65**
- LK-009 Banjo Fittings -10 mm to -3AN \$15.95**
- LK-010 Banjo Bolt Kit -7/16-20 to -3AN \$10.95**
- LK-011 Banjo Fittings -7/16 to -3AN \$17.95**
- LK-012 Adapters -4 Male to 45 Swivel \$21.65**
- LK-013 Adapters -3AN to 1/8" NPT Male \$10.95**
- LK-014 Adapters -4AN to 1/8" NPT Male \$10.95**

Call 402.886.2275 or click: www.heinzmanstreetrods.com

Hot Rod Brake Components