

Call Heinzman Street Rod Shop for 1965-70 Mustang suspension parts and accessories or if you would like to update your 'stang with more modern suspension, brakes and steering. We do complete Mustang restorations and late model Cobra engine swaps.

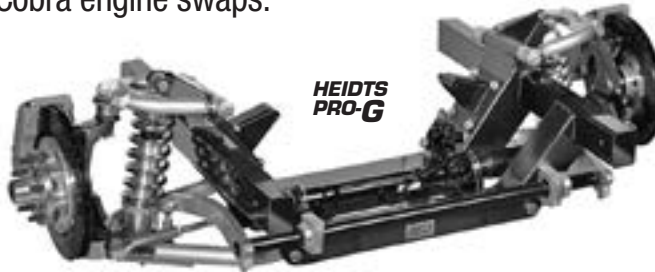

**HEIDTS PRO-G**

### HEIDTS PRO-G FULL FRONT SUSPENSION KIT FOR 1964-1/2 TO 70 MUSTANGS

HEIDTS New Pro-G kits are designed from the ground up with race car designed geometry and a narrower track for wider tires. Base kit includes the crossmember, 2" dropped spindles, plain steel tubular upper & lower arms, power rack & pinion, 11" Wilwood disc brakes, billet coil-over shocks with chrome springs (choice of spring rates) and motor mounts for popular Ford engines, inner fender panels.

**MTF-101 1964-1/2 -70 Mustang base kit . . . . . \$4,595.00**

*A few of the many options include:*

**CF-103 Stainless steel control arms . . . . . \$1,600.00**

**DF-222-D-B 12" Wilwood drilled rotors, 4 piston black calipers . . . . . \$410.00**

**DF-223-D-B 13" Wilwood drilled rotors, 6 piston calipers, black or polished . . . . . \$1,480.00**

**SB-403 Splined Sway Bar . . . . . \$625.00**



**HEIDTS PRO-G**

### HEIDTS PRO-G INDEPENDENT REAR SUSPENSION KIT FOR 1964-1/2 TO 70 MUSTANGS

The Heidts PRO-G IRS system will totally transform your early Mustang. This is a bolt-in high-horsepower unit and includes sub-frame connectors that stiffen the body and locate the suspension. Included is a 9" Aluminum housing, posi-traction iron 3rd member, your choice of ratios, Wilwood 10.5" disc brakes, CV joint axles, billet adjustable coil-overs, crossmember and brackets, front pinion support and more. Track is 56.5".

**IRM-101 1964-1/2 -70 Mustang- plain rotors . . \$9,210.00**

**PX-330-E with drilled and slotted rotors . . . . . \$9,550.00**

**Parking Brake kit available, please call.**

*Kits are not painted or assembled.*



### HEIDTS MUSTANG II IFS KIT FOR 1960-65 FALCON 1964-1/2 TO 70 MUSTANGS, 1967-70 COUGAR

HEIDTS suspension systems will give your Mustang, Cougar or Falcon the ride, handling and stopping power you are after. *Base kits include:* HEIDTS crossmember, 2" dropped spindles, tubular upper and lower arms, 11" rotors (Ford or Chevy bolt pattern), with single piston calipers, manual rack & pinion steering, stock shocks and springs

*\*Note: Rear sump style oil pan required. May not clear stock hood with some intakes. Ford 351 Cleveland's will not fit with these kits!*

**PX-320-EK 1964-1/2 -70 Mustang base kit . . . . . \$2,255.00**

**PX-330-EK 1964-65 Falcon base kit . . . . . \$2,255.00**

*A few of the many options include:*

**CA-112-SS Stainless steel control arms . . . . . \$1050.00**

**DF-202-DBK 11" Wilwood drilled rotors, black 4 piston calipers (red and polished available) . . \$765.00**

**DF-206-DBK 13" Wilwood drilled rotors, black 6 piston calipers (red and polished available) . . \$1,585.00**

**MP-038-VCK Chrome power rack and pinion . . . . . \$461.00**

**BS-002 Springs and coil-over shocks . . . . . \$370.00**

**BS-061 Sway Bar, plain . . . . . \$200.00**

### HEIDTS SUPERIDE II IFS KIT FOR 1964-1/2 TO 70 MUSTANGS

HEIDTS kits include the crossmember and Boxing plates, 2" dropped spindles, plain steel tubular upper & lower arms or narrowed control arms, manual rack & pinion steering, 11" iron rotors with 4 piston Wilwood calipers (Ford or Chevy bolt pattern), billet single adjustable coil-over shocks with chrome springs (choice of spring rates).

*\*Note: Rear sump style oil pan required. May not clear stock hood with some intakes. Ford 351 Cleveland's will not fit with these kits!*

**BX-320 1964-1/2 -70 Mustang base kit . . . . . \$3,195.00**

*A few of the many options include:*

**BS-026 Stainless steel control arms . . . . . \$1100.00**

**DF-202-DBK 11" Wilwood drilled rotors, black 4 piston calipers (red and polished available) . . \$431.00**

**DF-202-DBK 13" Wilwood drilled rotors, black 6 piston calipers (red and polished available) . . \$1,525.00**

**MP-038-VCK Chrome power rack and pinion . . . . . \$461.00**

**BS-002 Polished billet coil-over shocks . . . . . \$75.00**

**BS-061 Sway Bar, plain . . . . . \$200.00**

1965-1970 Ford Mustang Suspension



### HEIDTS MUSTANG II CROSSMEMBER FOR 1960-65 FALCON, 1964-1/2 TO 70 MUSTANGS, 1967-70 COUGAR

Specially designed your Mustang, Cougar or Falcon with correct geometry built in. Includes weld in front boxing plates

- PX-320-E 1964-1/2 -70 Mustang base kit . . . . . \$449.00
- PX-330-E 1964-65 Falcon base kit . . . . . \$449.00



### SWAY BAR FOR HEIDT'S FRONT ENDS

- SB-065 Sway bar . . . . . \$250.00



### INNER FENDER FILLER PANELS

Fills in the space where shock towers were.

- PX-325 1964-1/2 -66 . . . . . \$59.00
- PX-326 1967-70 . . . . . \$59.00



### SUB FRAME CONNECTORS

For use with Heidts front and rear suspensions

- RM-102 Mustang Coupe or Fastback . . . . . \$250.00
- RM-103 Mustang Convertible . . . . . \$250.00
- RF-102 Falcon . . . . . \$250.00



### FORD MOTOR MOUNTS

For use with Heidt's front crossmembers

- MM-131 Motor Mount Stands for SB Ford . . . .pair \$79.00
- MM-135 Rubber Motor Mounts -SB Ford . . . .pair \$45.00

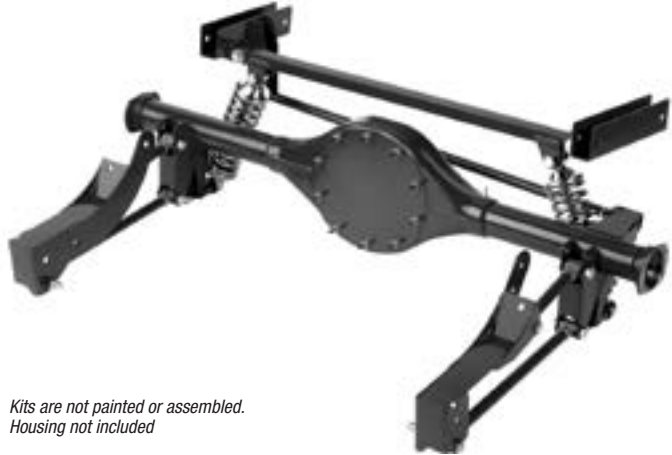

*Kits are not painted or assembled.  
Housing not included*

### HEIDTS REAR FOUR-LINK KIT FOR 1960-65 FALCON, 1964-1/2 TO 70 MUSTANG

Bolt on maximum performance for your Mustang or Falcon. *Kit includes* chassis and axle brackets, adjustable links, full upper coil-over crossmember, panhard bar, adjustable HEIDTS coil-overs and all hardware. Completely bolt-on, with no cutting or floor modifications. Adjustable 4-link mounts allow suspension tuning. Brackets must be welded to housing or housing with brackets installed is available. Will not fit Falcon Convertible, Ranchero or Cougar

- RM-101 1964 1/2 - 70 Mustang . . . . . \$1,495.00
- RF-101 1960-65 Falcon . . . . . \$1,495.00

*Many brake, axle housing and spring options are available*



*Kits are not painted or assembled.*

### HEIDTS SUPERIDE II IFS KIT FOR 1966-67 FAIRLANES ,COMETS

HEIDTS crossmember and boxing plates, stock spindles (2" dropped spindles optional), plain steel tubular upper & lower arms or narrowed control arms, power rack & pinion steering, 11" iron rotors with 4 piston Wilwood calipers (Ford or Chevy bolt pattern), billet single adjustable coil-over shocks with chrome springs (choice of spring rates).

- BX-601 1966-67 Fairlane / 66-67 Comet . . . . \$3,380.00

*Options are similar to other Superide II kits:*



1965-1970 Ford Mustang Suspension

1964-1973 Ford Mustang Suspension

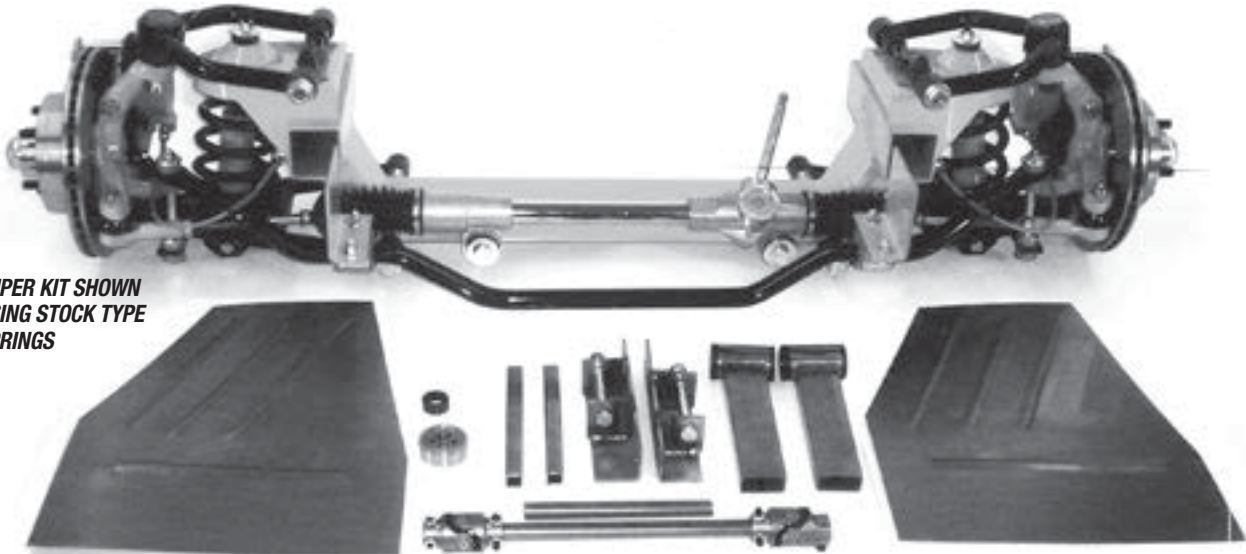

**SUPER KIT SHOWN USING STOCK TYPE SPRINGS**

*Kits are not painted or assembled.*



**BASE KIT SHOWN USING COIL-OVER SHOCKS**

**ROD & CUSTOM MOTORSPORTS MUSTANG II IFS KITS FOR 1964-73 MUSTANGS, 1960-70 FALCON/COMET, 1962-71 FAIRLANES, 1967-70 COUGARS**

These Mustang II based kits use the stock springs and shocks and tubular control arms. By using this kit, you gain 7" of room on each side of the engine! *Base kits include:* crossmember, springs, shocks, upper and lower arms, manual rack with bushings and ends, spindles with nut kit, bearings and seals, 11" disc brake kit.

**RC-103 Base kit . . . . . \$2,100.00**

**SUPER KITS**

These kits include everything in the base kit *plus:* motor mounts, 1" sway bar kit, tower replacement panels, stainless steel flex brake lines, steering shaft kit, column modification kit. *Options available:* larger brakes, powder coated arms, 2" dropped spindles, tilt column, and oil pans.

**RC-106 Super kit (shown) . . . . . \$2,695.00**

**ROD & CUSTOM MOTORSPORTS COIL-OVER KITS**

These kits fit same applications as the stock coil spring kits. They also include adjustable coil-over upper mounts and coil-over shocks and springs.

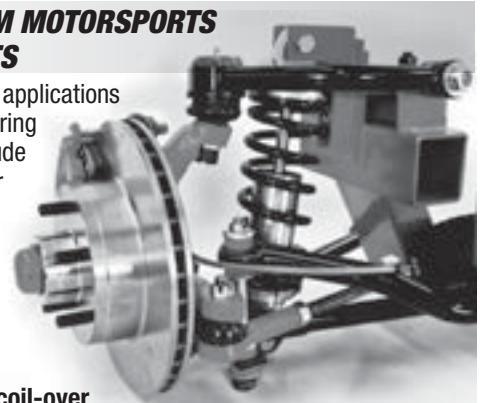

**RC-104 Base coil-over kit (Shown) . . . . . \$2,395.00**

**RC-107 Super coil-over kit . . . . . \$2,995.00**  
**Power Rack (additional) . . . . . \$100.00**



### ROD & CUSTOM MOTOR SPORTS MUSTANG II IFS CROSSMEMBER ONLY

Use this kit if you have your own components. Fits same applications as the complete kits. Available for stock coil springs or coil-overs.

- RC-101 Crossmember for stock style springs . . \$495.00
- RC-102 Crossmember for coil-over springs . . . \$495.00



### ROD & CUSTOM MOTOR SPORTS REAR COIL-OVER KIT FOR 1960-65 FALCON & COMET, 1964-70 MUSTANG & COUGAR

This is a true bolt-in kit that uses the original rear end housing spring pads to mount the lower bars and coil over brackets. The upper bars mount to a bracket that bolts to the center section. Very easy to install. Includes sway bar.

- RC-114 Rear coil-over kit . . . . . \$1,695.00

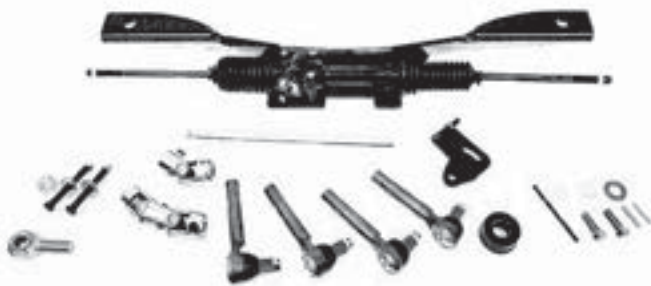

### UNI-STEER RACK AND PINION KITS

These kits are for use with the stock front crossmember and suspension. Uni-Steer kits are true bolt-ons and easy to install. They will transform the handling and steering feel of your classic Ford.

#### 1965-70 MUSTANG KITS

- 8001110-01 1965-66 Manual . . . . . \$1049.00
- 8001090-01 1967-70 Manual . . . . . \$1049.00
- 8010890-01 1965-66 Power, small block. . . . . \$1599.00
- 8010830-01 1967-70 Power, small block. . . . . \$1599.00
- 8010900-01 1965-66 Power, big block . . . . . \$1599.00
- 8010920-01 Late 1967-70 Power, big block . . . . . \$1599.00



### BOOSTER/MASTER CYLINDER ASSEMBLIES

These new units include the mounting bracket and push rod. They are designed to use the original manual brake pedal and have the correct pedal ratio. Available with a drum or disc mater cylinder.

- DB107 1964-67 Mustang, 7", disc/drum . . . . . \$259.00
- DB107-D 1964-67 Mustang, 7", disc/disc . . . . . \$259.00
- DB108 1967-70 Mustang, 9", disc/drum . . . . . \$259.00
- DB108-D 1967-70 Mustang, 9", disc/disc . . . . . \$259.00



### 1965-70 MUSTANG TILT STEERING COLUMN

These new columns use all new parts and are available in paintable steel or polished stainless. Requires steering shaft and couplers/U-joints.

- FR20005 1965-66 . . . . . \$369.00
- FR20004-69 1967-70 . . . . . \$369.00



### HIGH-POWER ELECTRIC BOOSTER AND MASTER CYLINDER ASSEMBLY

This high pressure system includes an electric remote booster that can be mounted anywhere in the car. This cleans up the firewall, frees up extra valve cover clearance and solves the low vacuum problem that many high performance engines have. Good looking, light weight and easy to install. Features a 1.125" bore, Dual circuits and built in metering/proportioning valve. Only 8" x 3.6" x 3.3".

- 10-56 Electric power brake booster/M.C. . . . . \$1,400.00

1964-1973 Ford Mustang Suspension