

1955-1957 Chevy suspension



CHASSIS ENGINEERING ENGINE MOUNTING KIT

Includes bolt on frame adapters (or can be welded on), engine side mounts, thru bolt cushion set, bolts and instructions. Easy to install. Engine sits in same location as original. Kit also fits Big Blocks.

CP-1112 Engine mounting kit \$130.00



TRANSMISSION MOUNTING KIT

1955-57 Chevy transmission crossmembers for any transmission

91628910 Transmission mounting kit \$95.00



HEIDTS TUBULAR UPPER A-ARMS

These tubular upper A-Arms are the ultimate in looks and a direct replacement for the stock originals. They include new design cross shafts which have offset built in to increase the amount of camber adjustment. All welds are heli-arc welded for maximum strength. The stainless arms are fully polished (except cross shafts). Arms are ready to install, including new cross shafts, ball joints and bushings.

CA-201 Tubular upper A-arms: plain pair \$415.00
CA-201SS Tubular upper A-arms: stainless pair \$800.00



HEIDTS TUBULAR LOWER A-ARMS

A perfect match to Heidt's upper A-Arms. For stock springs or coil-overs. The lower ball joint is the correct compression type, not a tension ball joint turned upside down. Lower arms include stabilizer tabs and steering stops welded in place and a stamped spring pocket. Also included are new cross shafts, ball joints and bushings and come fully assembled, ready to install. Stainless steel arms are fully polished.

CA-203 Tubular lower A-arms: plain pair \$725.00
CA-203SS Tubular lower A-arms: stainless . pair \$1,450.00
CA-203-M Plain for coil-over shocks pair \$725.00
CA-203-SS-M Stainless steel for coil-over shocks. pr \$1,450.00



QA1 COIL OVERS

Billet coil-over shocks have fully adjustable dampening. Silver powder coated full length progressive springs assure full travel and smooth ride with spring rates for small block and big block. They also fit stock lower arms using adapter kit CS-020.

GS501 Coil-over shocks pr \$529.00
450# 11" Coil-over springs, small block included
550# 11" Coil-over springs, big block included

Springs are available in 300-700 lb increments

HEIDTS 2" DROPPED STEEL SPINDLES

2" Dropped Steel Spindles are full steel spindles, just like factory spindles. This is much stronger than cast iron. They use your stock steering arms, with no loss of turning radius. No realignment required. The caliper brackets bolt on like mid-70's Chevys, allowing many brake options. Also available as a kit with late model GM caliber brackets.

SP-102 Spindles \$359.00
SP-102B Spindle kit with early Chevelle brackets . . \$359.00



1" DROPPED COIL SPRINGS

To give your "Shoebox" an even lower look, add these Heidts 1" dropped coil springs. Combined with Heidts 2" dropped spindles, they will put your cruiser a full 3" in the weeds safely and easily. For use with either sock arms or our tubular A-Arms.



CS-060 Dropped stock style springs \$99.00



STABILIZER BAR KITS

Stabilizer bars, or sway bars, are used to help control body roll and sway. Heidts Stabilizer Bars for 1955-57 Chevys are made of heat treated steel and are gold zinc plated. They are available in either 7/8" or 1" bar, with either rubber or urethane bushings.

SB-050-U 7/8" bar, urethane bushings \$159.00
SB-051-U 1" bar, urethane bushings \$159.00
SB-052-U Rear stabilizer bar kit \$159.00

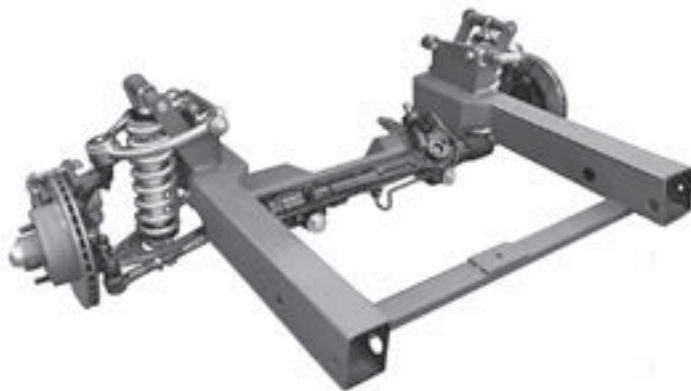

1955-56 CHEVY FATMAN MUSTANG II FRONT STUBS

Tri-Five Chevys have a frame design which doesn't allow for a simple Mustang II crossmember installation, yet are too narrow for a GM sub-frame. Fatman builds these weld-on clips which provide a 2-4" drop, and include pre-made mounts for bumpers, radiators and front sheet metal. Stock sheet metal remounts with very minor, or no trimming required. Please call for details.

Complete kit with stock springs \$2,995.00
Complete kit with coil overs \$3,450.00

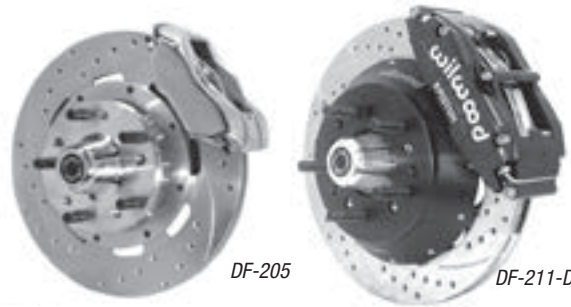

WILWOOD DISC BRAKE KITS

The ultimate upgrade for Heidts dropped spindles. Includes: Wilwood polished aluminum calipers with pads, polished aluminum hubs with 11" vented rotors, bearing and seals, caliper brackets and hardware. Braided stainless lines sold separately.

DF-205 11" Wilwood drilled rotors, 4 piston polished calipers & hardware \$895.00
DF-205-D 11" Wilwood drilled rotors w/ polished hubs, 4 piston polished calipers & hardware . . \$1,050.00
DF-210-D 12" Wilwood drilled rotors w/ polished hubs, 4 piston polished calipers & hardware . . \$1,075.00
DF-211-D 13" Wilwood drilled rotors w/ black hubs, 4 piston black calipers & hardware . . . \$1,995.00



POWER BOOSTER & DUAL MASTER CYLINDER

Power Brakes for you 1955-57 Chevy. Kit includes: power booster, dual master cylinder and correct proportioning valve for disc-drum or disc-disc cars. Designed for use with our disc brake kits. Fully assembled and plumbed, ready for installation.

DB-116 Power booster, master cyl, disc/drum . . . \$329.00
DB-116D Power booster, master cyl, disc/disc . . . \$329.00
DB103 Manual master cylinder, disc/drum \$159.00
DB103D Manual master cylinder, disc/disc \$159.00



ECI DISC BRAKE KITS FOR STOCK SPINDLES

Uses 1969-72 Chevelle/ Monte Carlo, 69-74 Nova rotor and caliper (or GM equivalents). Caliper brackets bolt to the stock spindles. No steering arm/tie rod relocating required. Replaces original ball bearings with late GM tapered roller bearings and grease seals.

EC-708 1955-58 Chevy, Bracket Kit \$175.00
EC-708CK Complete Kit \$460.00

1955-1957 Chevy Suspension

1955-1957 Chevy suspension



ECI POWER BOOSTER/MASTER CYLINDER

These systems come complete with new 7" booster and master cylinder assemblies and adapter brackets. They mount in the stock location and the original brake pedal is utilized. 9" booster is also available for 60% more assist (for small blocks only).

- EC-600** 1955-64 Chevy **\$295.00**
- EC-605** 1955-64 Chevy w/9" power booster **\$325.00**



UNI-STEER RACK & PINION CONVERSION KIT

Uni-steer's Tri-5 rack and pinion will greatly improve handling and steering effort, while maintaining road feel. This kit is specifically designed for the Tri-5's with the correct ball center dimension so there is no bump steer. Best of all, this is a BOLT-ON kit, no chassis modifications necessary. a manual rack is also available, recommended for racing.

- 8010400-01** Tri-5 Power rack & pinion kit **\$862.92**
- 8000230** Tri-5 Manual rack & pinion kit **\$930.00**



GM 600 BOX POWER STEERING KIT

Bolt-in conversion kits use a remanufactured GM 600 power steering box modified to bolt to the 1955-57 Chevy frame. This is the newest technology from GM with a sporty 12.7:1 or 14:1 ratio for a modern steering feel. Cars with factory power steering require a drag link adaptor. Kit includes 600 power steering box, P/S pump with pulley and brackets, hoses and rag joint and column floor mount.

- 999009** 600 Power steering complete kit, 12.7:1 .. **\$991.00**
- CPP 600 Power steering gear only, 14:1 .. \$449.00**



HEIDTS REAR TRIANGULATED 4-LINK KIT

HEIDTS 1955-57 chevy car triangulated 4-link kit is very popular because it does not require a panhard rod. Kit includes fully adjustable, 1-1/4" X .156 tube 4-bars with 3/4" stainless adjusters and urethane bushings, angled and straight chassis brackets, upper crossmember, standard black coil-overs and springs, tabs and hardware. These kits are available in plain steel or polished stainless steel tubes, plain or polished billet shocks and chrome springs. NOTE: Intended for stock or aftermarket frames. Also available with fully welded housing, 3rd member, axles and brakes. Please call.

- RC-151** 1955-57 Chevystarting at **\$1,500.00**



FLAMING RIVER TILT STEERING COLUMNS

Bolt-in column is Made-in-the USA from all new components. Includes the correct plug for your harness, turn, tilt levers, flasher button. Available, plain steel, chrome, black powder coated, brushed aluminum, polished aluminum.

- Column for floor shift** from **\$369.00**
- Column with column shift** from **\$647.00**



ALUMINUM RADIATORS AND ASSEMBLIES

Beautifully made high-performance aluminum radiators made by Performance Rod & Custom. These custom made radiators are designed to cool big motors in extreme conditions or just cruising around. Just the radiator is available or as a complete assembly with a replacement core support, splash apron and filler panels. Lots of extras are available such as electric fans, A/C condensers and trans coolers. Please call.

- 2110055** Radiator/core support assembly, basic. . . **\$695.00**