

## ALAN GROVE ALTERNATOR & AIR-CONDITIONING MOUNTING BRACKETS

Alan Grove brackets offer straight forward engineering and quality craftsmanship at an affordable price. All brackets are made from steel plate, T.I.G. welded and hand finished. All hardware, instructions and belt recommendations are included. Chevy kits listed are for short water pumps. Long water pump kits are also available.

### A/C AND ALTERNATOR BRACKETS

**SMALL BLOCK CHEVY** bolts to top water pump and intake bolts

100R-AC	A/C bracket, Right	\$99.00
100L-AC	A/C bracket, Left	\$99.00
200R-ALT	Alternator bracket, Right	\$90.00
200L-ALT	Alternator bracket, Left	\$90.00
	Combination alternator-A/C Brackets	\$190.00
	Extra clearance brackets	\$190.00

**BIG BLOCK CHEVY** bolts to heads and top water pump bolts

104R-AC	A/C bracket right	\$99.00
204L-ALT	Alternator bracket left	\$85.00

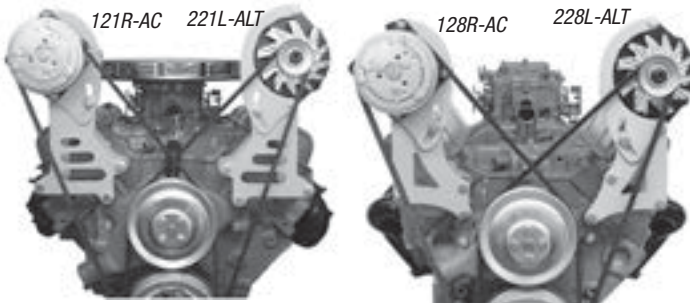

### HEAD MOUNT A/C AND ALTERNATOR BRACKETS

Bolts to heads and top water pump bolts instead of intake manifold.

#### SMALL BLOCK

128R-AC	A/C bracket 1969 and newer, GM aluminum	\$99.00
129R-AC	A/C bracket 87-up iron & Vorteck	\$99.00
228L-ALT	Alternator Bracket	\$99.00

#### BIG BLOCK extra clearance

121R-AC	A/C bracket	\$99.00
221L-ALT	Alternator bracket	\$99.00

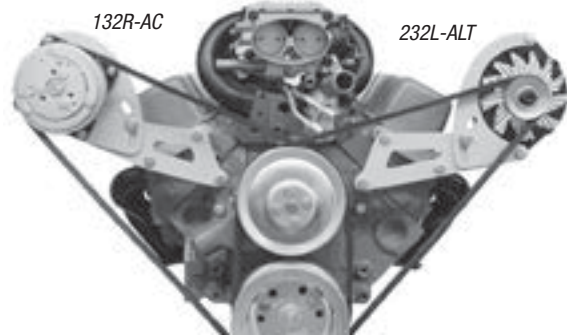

### LOW HOOD CLEARANCE A/C AND ALTERNATOR BRACKETS

Designed for cars with a wide engine compartment and low hood clearance, Vettes, Camaros, Trucks, 50 - 60's cars, etc. The alternator bracket will fit all 1969 and newer heads. The small block A.C. Compressor bracket fits all G.M. aluminum heads including the fast-burn aluminum heads and may be used on 1969 thru 1986 cast iron heads by drilling and tapping one hole for the upper mounting point.

**SMALL BLOCK** These brackets bolt to the head and top water pump bolt holes.

132R-AC	A/C bracket	\$99.00
232L-ALT	Alternator brkt all 1969 and newer heads	\$99.00
133R-AC	A/C bracket 87-up iron & Vorteck	\$99.00

**BIG BLOCK** These brackets bolt to the head and top water pump bolt holes.

118R-AC	A/C bracket	\$99.00
218L-ALT	Alternator bracket	\$99.00

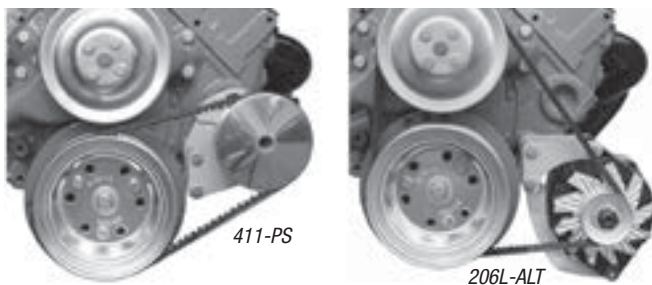

### LOWER ALTERNATOR AND POWER STEERING BRACKETS

#### SMALL BLOCK

206L-ALT	Low alternator mount, left	\$75.00
206L-ALT	Low alternator mount -lower and tighter	\$75.00
209L-ALT	Low alternator mount for GM-CS130 Alt.	\$75.00
400L-PS	Power steering bracket, left	\$80.00
409L-PS	Power steering bracket, left, Type II pump	\$80.00

#### BIG BLOCK

208L-ALT	Low alternator mount, left	\$75.00
210L-ALT	Low alternator mount for GM-CS130 Alt.	\$75.00
430L-PS	Power steering bracket, left	\$80.00
415L-PS	Power steering bracket, left, Type II pump	\$80.00



### SMALL BLOCK FORD A/C BRACKET

Brackets bolt to 289, 302, 351 Windsor heads and adjusts front to rear for different timing cover and pulley combos.

105L-AC	\$100.00
105R-AC	\$100.00



### CONCEPT ONE "VICTORY SERIES" PULLEY SYSTEM

Victory Series serpentine pulley system is designed to keep the A/C compressor, alternator and power steering pump tucked within the boundary of the engine block. These kits are intended to fit a wide variety of applications from street rods to late model trucks as long as there is sufficient room between the engine and the radiator.

*Kits include* • Polished Sanden A/C compressor • New Delphi PS pump with billet reservoir • Edelbrock water pump • 105 amp polished alternator • billet crank, water pump, PS pulleys • billet brackets • alternator fan and pulley cover • compressor cover • belt and tensioner • chrome hardware. Available polished, machined finish or anodized clear or black.

SCV01P	Chevy SB w/PS, Polished or anodized . . . . .	\$2,295.00
SCV01M	Chevy SB w/PS, Machined. . . . .	\$2,145.00
SCV02P	Chevy SB w/o PS, Polished or anodized. . . . .	\$1,945.00
SCV02M	Chevy SB w/o PS, Machined . . . . .	\$1,745.00
BCV01P	Chevy BB w/PS, Polished or anodized . . . . .	\$2,245.00
BCV01M	Chevy BB w/PS, Machined . . . . .	\$2,045.00
SCV02P	Chevy BB w/o PS, Polished or anodized . . . . .	\$1,895.00
SCV02M	Chevy BB w/o PS, Machined . . . . .	\$1,745.00
LSV01P	Chevy LS w/PS, Polished or anodized . . . . .	\$2,695.00
LSV01M	Chevy LS w/PS, Machined. . . . .	\$2,375.00
LSV02P	Chevy LS w/o PS, Polished or anodized. . . . .	\$2,295.00
LSV02M	Chevy LS w/o PS, Machined . . . . .	\$2,045.00

### CHEVY ENGINE PULLEYS

Factory GM black steel pulleys. Small block and big block with short water pump. Serpentine pulley sets are for long water pumps.

500	2 groove water pump, Small/Big Block . . . . .	\$50.00
501	2 groove crank, Small Block . . . . .	\$45.00
501B	2 groove crank, Big Block. . . . .	\$55.00
502	1 groove crankshaft power steering Small/Big Block . . . . .	\$40.00
506	2 groove Power steering, bolt-on. . . . .	\$40.00
509	2 groove Power steering, press-on. . . . .	\$47.00
510	Serpentine set, Small Block water pump, crankshaft power steering and alternator. . . . .	\$135.00
511	Serpentine set, Small Block water pump, crankshaft and alternator . . . . .	\$100.00



*"Please call for dimensions and details on any of these kits."*

### CONCEPT ONE "STREET ROD" PULLEY SYSTEM

Street Rod Kits are one belt serpentine kits designed for street rods and other vehicles with tight engine compartments. These compact setups keep the A/C compressor and alternator in close to the engine and set back as far as possible to allow clearance for radiators and electric fans. Reverse flow water pumps are used for improved cooling. Kits are available for standard small block cast iron and aluminum heads, as well as Vortec heads.

*Kits include* • New Delphi PS pump with billet reservoir • Edelbrock water pump • billet crank, water pump, PS pulleys • billet brackets • alternator fan and pulley cover • compressor cover • belt • chrome hardware. Available polished or machined.

SCR01P	Chevy SB w/PS, Polished. . . . .	\$1,295.00
SCR01M	Chevy SB w/PS, Machined. . . . .	\$1,150.00
SCRV01P	Chevy SB Vortech w/PS, Polished. . . . .	\$1,295.00
SCRV01M	Chevy SB Vortech w/PS, Machined. . . . .	\$1,150.00
SCR02P	Chevy SB w/o PS, Polished . . . . .	\$895.00
SCR02M	Chevy SB w/o PS, Machined . . . . .	\$750.00
SCR02P	Chevy SB Vortech w/o PS, Polished . . . . .	\$895.00
SCR02M	Chevy SB Vortech w/o PS, Machined . . . . .	\$750.00
BCR01P	Chevy BB w/PS, Polished. . . . .	\$1,295.00
BCR01M	Chevy BB w/PS, Machined . . . . .	\$1,150.00
SCR02P	Chevy BB w/o PS, Polished . . . . .	\$895.00
SCR02M	Chevy BB w/o PS, Machined . . . . .	\$750.00

### CONCEPT ONE SMALL BLOCK FORD PULLEY SYSTEM

These one belt systems fit a wide variety of applications including street rods, trucks, Mustangs and practically anything else a small block Ford will fit into. **Versions for short and long water pump and without power steering and/or AC.**

*Kits include* • Polished Sanden A/C compressor • New Delphi PS pump with billet reservoir • 105 amp polished alternator • billet crank, water pump,

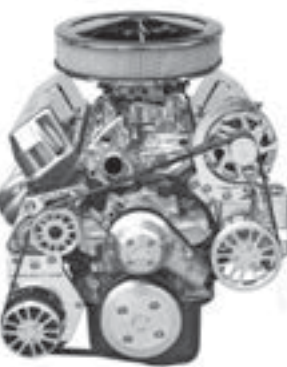

PS pulleys • billet brackets • alternator fan and pulley cover • belt • compressor cover • chrome hardware. Available polished or machined. **Specify 289/302 or 351 Windsor. Also available for Cleveland, FE and 429/460 Big Blocks.**

SFL01P	Ford SB w/PS, long WP Polished. . . . .	\$2,195.00
SFL01M	Ford SB w/PS, long WP Machined . . . . .	\$1,995.00
SFM01P	Ford SB w/PS, short WP Polished . . . . .	\$2,145.00
SFM01M	Ford SB w/PS, short WP Machined. . . . .	\$1,995.00
SFL02P	Ford SB w/o PS, long WP Polished . . . . .	\$1,795.00
SFL02M	Ford SB w/o PS, long WP Machined . . . . .	\$1,595.00
SFM02P	Ford SB wo /PS, short WP Polished . . . . .	\$1,795.00
SFM02M	Ford SB w/o PS, short WP Machined . . . . .	\$1,595.00

**Call 402.886.2275 or click: [www.heinzmanstreetrods.com](http://www.heinzmanstreetrods.com)**

Engine Accessory Drives and Pulleys

## THE VINTAGE AIR FRONTRUNNER SERPENTINE DRIVE SYSTEM

**FOR ANY HOT ROD, CUSTOM, OR CLASSIC TRUCK.**

Vintage Air's Front Runner Drive System was engineered to convert any small block and big block Chevrolet and small block Ford engine to the popular and more dependable serpentine belt design. The modular design, based on the latest CAD/CAM architecture, places all driven components in the tightest possible configuration. Systems are available in a short or long pump style and with or without power steering.



## CHEVY LS FRONT RUNNER DRIVE SYSTEM

The LS Front Runner™ features the smallest component package available for easier engine swaps into older vehicles. *LS kits include* • Vintage Air's exclusive machined truss-type mounting bracket • Stewart high performance water pump • power steering pump • SD7 compressor • 140 amp alternator • aluminum pulleys • ATI harmonic balancer • ARP polished stainless bolt kit • Dayco serpentine belt. For all 5.3L, 5.7L, 6.0L, 6.2L and 7.0L GM LS Series engines.

- 174014** With power steering, bright finish . . . . . \$2,895.00
- 175015** Non power steering, bright finish . . . . . \$2,675.00
- 174011** With power steering, black hard coat . . . . \$2,795.00
- 175011** Non power steering, black hard coat . . . . \$2,575.00

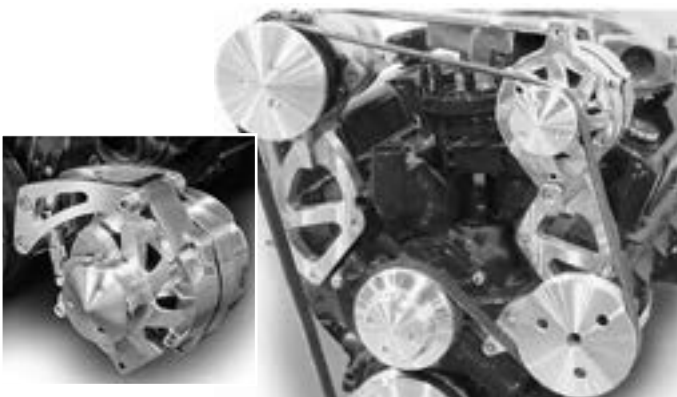

## MARCH PERFORMANCE PULLEYS AND BRACKETS

March has a huge selection of complete drive systems, Brackets and pulleys. Way to many to list here. We can set you up with whatever you need so give us a call.

**They have kits for:** • Chevy Small Block • Chevy Big Block • Chevy LS • Chevy LT1 • Ford Small blocks, Cleavelands and Windsors • Ford Flatheads • Buick • Olds • Chrysler Wedge and Hemis



## CHEVY SMALL BLOCK AND BIG BLOCK FRONT RUNNER DRIVE SYSTEMS

The exclusive truss bracket bolts to the block instead of the head or intake manifold solving the problem of various small block Chevy head and intake configurations.

*Kits include* • machined truss-type mounting bracket • Stewart high performance water pump • power steering

pump and bracket • SD7 compressor with formed hardlines and clutch cover • 140 amp alternator • aluminum pulleys • OEM belt tensioner with cover • ARP polished stainless bolt kit • Dayco serpentine belt • extended heater hose nipple. Note: Not for LT1 engines.

### SMALL BLOCK

- 174015** With power steering, bright finish . . . . . \$2,265.00
- 174008** With power steering, black hard coat . . . \$2,045.00
- 175020-SCA** Non power steering, bright finish . . . . . \$2,075.00
- 175010-SCA** Non power steering, black hard coat . . . \$2,095.00

### BIG BLOCK

- 174058** With power steering, bright finish . . . . . \$2,380.00
- 174048** With power steering, black hard coat . . . \$2,330.00
- 175060-BCA** Non power steering, bright finish . . . . . \$2,190.00
- 175050-BCA** Non power steering, black hard coat . . . \$2,140.00



### SMALL BLOCK FORD FRONT RUNNER DRIVE SYSTEM

- 174100** w/ PS, bright . . . . . \$2,640.00
- 174101** w/ PS, black . . . . . \$2,615.00
- 175103-SFA** w/o PS, bright . . . . . \$2,350.00
- 175102-SFA** w/o PS, black . . . . . \$2,375.00



## S&P PULLEYS, BRACKETS AND DRIVES

We use a lot of Street & Performance products in our shop builds. They have complete drive kits, pulleys and brackets for Chevy small and big blocks, Chevy LS, Chevy LT1, Ford small blocks and big blocks and Mopar Hemis. They have many solutions for Chevy LS engine swaps. Call with your problem and we can help you out!

**Small Block Chevy alternator only** V-belt brackets, pulleys and hardware, polished . . . . . \$387.95

**LS street rod drive system** including Alt, AC and PS pump, many combinations, polished . . . . . \$1,940.95

**Big Block street rod V-belt drive system** including Alt, AC and PS, many combinations, polished . . . . . \$1,473.95