

WESCOTT FIBERGLASS BODIES

Westcott bodies feature hand laminated fiberglass with an internal steel support structure. Westcott does not use wood glued to the inside of the body that can show through. Bodies are made up of panels that mimic the stock steel panels to eliminate stress and expansion-contraction issues. The bodies are designed to fit original or reproduction Ford frames. The doors and deck lid are fitted and hinged and come with modern "Bear Jaw" style latches. Complete top iron kits are available for roadster and convertible bodies.

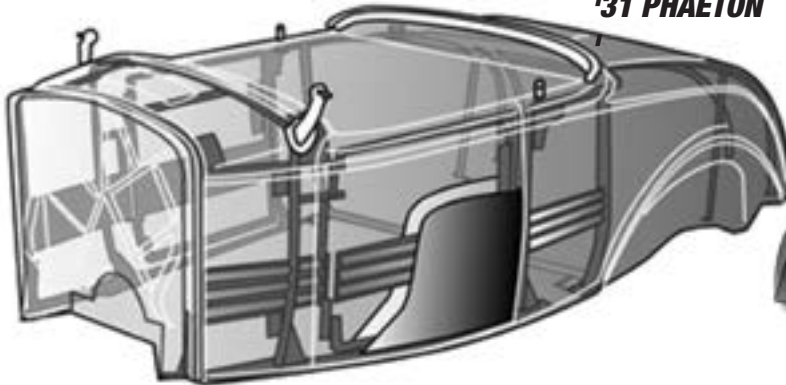

'26 "T" ROADSTER

'29 ROADSTER

'29 ROADSTER PICKUP

'29 PHAETON

'31 ROADSTER

'31 ROADSTER PICKUP

'31 PHAETON

'31 5-WINDOW COUPE

'32 ROADSTER

'32 HIBOY SPECIAL

'32 PHAETON

'32 3-WINDOW COUPE

'34 ROADSTER

'39 CONVERTIBLE

'40 CONVERTIBLE



1932 ROADSTER BODY

Street rod style. Includes the lower windshield posts and top mounts for the traditional style windshield frame, and posts and top brackets for the folding top irons.

Please specify options when ordering.

- A. Firewall: "stock" style or recessed "flat" style
- B. Seat: stock or 2" extra seat setback
- C. Deck lid: rumble or trunk lid
- D. Dash: "stock," "flat," or "auburn" style
- E. Cowl: working vent or filled cowl
- F. Door: stock (outside or hidden hinges)
- G. Deck latch: stock or remote style

1932 Roadster replica body.....\$9,500.00

Working cowl vent..... extra \$200.00

1932 Fender Package.....\$1,750.00

includes: 1 pair front fenders • 1 pair rear fenders • 1 grille shell (specify filled or stock grille shell) 1 front apron (specify standard or chop) 1 pair rear frame horn covers



1932 THREE-WINDOW COUPE BODY

Available with a stock height or chopped 2.5" in front and 2" rear filled top.

Please specify options when ordering.

- A. Firewall: "stock" modified stock or recessed "flat" style
- D. Dash: "stock," "filled," or with or without glove box
- E. Cowl: working vent or filled cowl
- F. Door: stock (outside) or hidden hinges
- G. Deck latch: stock or remote style

1932 Roadster replica body.....\$18,500.00

Working cowl vent..... extra \$200.00

Working glove box..... extra \$200.00

1932 Fender Package.....\$1,750.00

includes: 1 pr front fenders • 1 pr rear fenders • 1 grille shell (Specify filled or stock grille shell) 1 front apron (specify standard or chop) 1 pair rear frame horn covers

Many more options..... please call



1933-34 ROADSTER BODY

Please specify options when ordering.

- A. Firewall: "stock", Chevy V8, Ford V8, or big block
- C. Deck lid: rumble or trunk lid
- D. Dash: 1933 or 1934 body, dash with glove box lid or filled
- E. Cowl: working vent or filled cowl
- F. Door: stock outside or hidden hinges

1934 Roadster replica body.....	\$11,200.00
Working cowl vent..... extra	\$200.00
Opening glove box lid..... extra	\$200.00
Front fenders, 1933 or 1934 style.....	\$580.00
Inner fenders, 1933 or 1934 style.....	\$195.00
Rear fenders.....	\$415.00
Gas tank cover, stock or smooth.....	\$145.00
Fiberglass package total.....	\$1,500.00



1939 AND 1940 CONVERTIBLE BODY

Wescott bodies feature hand laminated fiberglass with an internal steel support structure. The body is designed to fit original or reproduction 1935-40 Ford frames – The doors and deck lid are fitted and hinged and come with modern "bear claw" style latches – The windshield is available stock height or with a 2" chop. Complete top iron kits are available for the 2" chop model

Please specify body type.

- 1939 Deluxe convertible with rumble lid
- 1939 Super deluxe convertible with trunk
- 1940 Deluxe convertible with space for back seat

Please specify options when ordering.

- A. Firewall: "stock," Chevy V8, Ford V8, or big block V8
- B. Dash: 1939 filled or 1940 filled style (both styles have opening glove box lids)
- C. Cowl: working vent or filled cowl
- D. Chop: stock height windshield or 2" chop

1939-40 Convertible replica body only	\$17,500.00
Working cowl vent..... extra	\$200.00
Fenders, inner fenders and hood (fiberglass) kit.	\$3,500.00
Power window kit (installed)	\$1,140.00
2" chop top iron kit for 1939 (installed).....	\$2,950.00
2" chop top iron kit for 1940 (installed).....	\$3,950.00

1939 "DeLuxe" Convertible two place with rumble seat lid

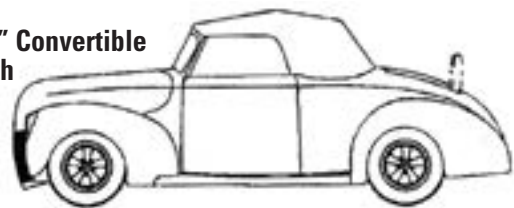

1939 "Super DeLuxe" Convertible two place with rumble seat lid

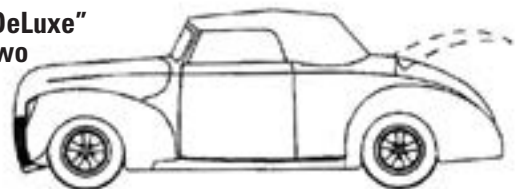

1940 "DeLuxe" Convertible four place with trunk lid

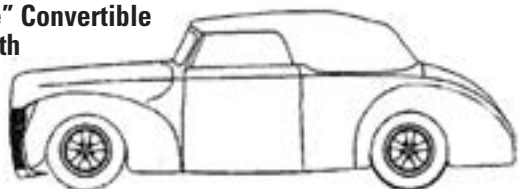

Call 402.886.2275 or click: www.heinzmanstreetrods.com

Wescott Fiberglass Bodies and Fenders